

# **Vacuum Packing Machines**

**(Tabletop versions)**

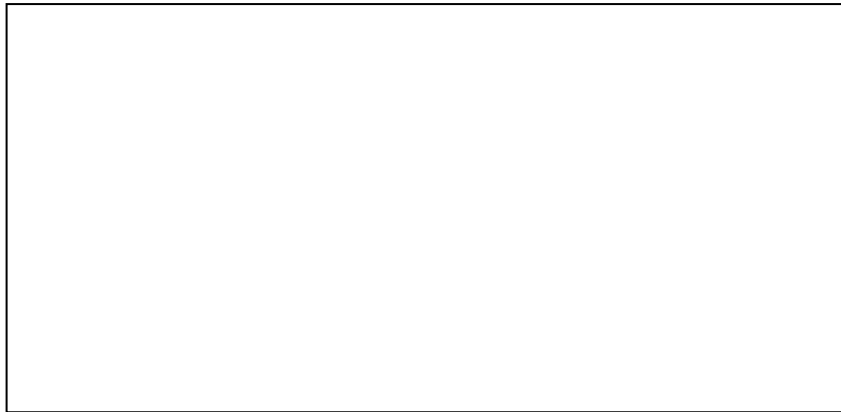

**Translation of the Original  
Operating Instructions**  
(Retain for future applications)



**Manufacturer:**

**Boss Verpackungsmaschinen  
GmbH & Co. KG  
Zum Wingert 5  
61352 Bad Homburg  
Germany**

<b>Headquarters:</b>	<b>Bad Homburg</b>
<b>Commercial Register:</b>	<b>A 2740</b>
<b>VAT ID No.:</b>	<b>DE 111293977</b>

**Contact:**

<b>Telephone:</b>	<b>+49 (0) 6172 – 457097</b>
<b>Fax:</b>	<b>+49 (0) 6172 – 44139</b>
<b>E-mail:</b>	<b><u><a href="mailto:info@vacuum-boss.com">info@vacuum-boss.com</a></u></b>

## Contents

- 1.0. EC Declaration of Conformity**
- 2.0. Safety**
  - 2.1. Intended use of the machine**
  - 2.2. Safety instructions**
    - 2.2.1. - for the erection of the machine**
    - 2.2.2. - for commissioning the machine post-delivery or post-relocation**
    - 2.2.3. - for operation of the machine**
    - 2.2.4. - for servicing and cleaning the machine**
    - 2.2.5. - for maintenance work**
    - 2.2.6. - for faults and repairs**
  - 2.3. Hazard warning signs**
  - 2.4. Emissions and disposal**
- 3.0. Working with vacuum packing machines**
  - 3.1. Adjustment of the machine control system**
    - 3.1.1. Control Z 1000 / Z 2000**
    - 3.1.2. Control Z 2001 SENSOR**
    - 3.1.3. Control Z 3000**
  - 3.2. Vacuum packing**
  - 3.3. Information on the packing of liquids**
- 4.0. Regular cleaning tasks**
  - 4.1. Regular maintenance tasks**
    - 4.1.1. Vacuum pump (control, oil service, oil change, changing the filter cartridges)**
    - 4.1.2. Lid seal**
    - 4.1.3. Sealing bar (equipping the sealing bar)**
- 5.0. Faults and troubleshooting**
  - 5.0.1. Leakages**
  - 5.0.2. Machine unable to create vacuum / loud sound from pump**
  - 5.0.3. Poor vacuum**
  - 5.0.4. No welding seam on bag**
  - 5.0.5. Bad welding seam**
  - 5.1. Removing of the machine control system**
- 6.0. Additional information for our service partners**

**1.0. EC Declaration of Conformity**  
**in accordance with Appendix II A of the EC Machine Directives**  
**(2006/42/EC, MachD)**

**Machine type: Vacuum packing machines**

**Please request the current declaration of conformity via**  
**[info@vacuum-boss.com](mailto:info@vacuum-boss.com)**

## **2.0. Safety**

**It is essential to comply with all the instructions in this chapter.**

The machines are intended solely for the vacuum packaging of products (as described in the section "Intended use of the machine"), in order to prevent personal injury, damage to the machine and/or damage to the product being packed.

Any other use is expressly prohibited.

**The machines must only be operated by fully trained and authorized persons.**

### **Danger!**

It is essential to ensure that no living organisms are in the vacuum chamber during the vacuuming process.

Danger of death!

## **2.1. Intended use of the machine**

Vacuum packing lines are chamber machines that enable the manufacture of airtight packaging.

The products are vacuum packed in special multilayer foil bags.

They are used to pack all kinds of foodstuffs, electrical components and chemical and technical products.

Because these vacuum packing lines are chamber machines, it is possible to achieve a vacuum of 99.5 % and more. This high, professional vacuum also means that the vacuum packing and its contents are subject to an external pressure of up to 1kg/cm<sup>2</sup>.

**Sensitive products may be damaged or destroyed by this level of pressure.**

In such cases, the machine must also be equipped with a gas flushing device (optional extra). As well as generating a vacuum, this device also enables modified atmosphere packing.

This means that – after the vacuuming process – a modified atmosphere (a mixture of gases specifically tailored to the product) is blown into the packing. This modified atmosphere balances out the external pressure and the product can be stored in a more favorable atmosphere.

**Use of the machine according to its intended purpose requires compliance with all the instructions pertaining to safety, operation and maintenance as described in these operating instructions.**

## **2.2. Safety instructions**

It is essential to ensure that these operating instructions are carefully read and understood before erecting the machine.

To prevent health risks and damage to the product or machine, it is important to comply with a number of instructions.

To simplify matters, we have broken these instructions down into different sections (e.g. Erection of the machine).

If your machine is equipped with any optional extras (such as a gas flushing device), it may be necessary to observe additional safety instructions, which you will find at the end of each section.

Should you have any further queries, please do not hesitate to contact us.

### **2.2.1. Safety instructions for the erection of the machine**

The machine must be securely placed on an even, nonskid, stable surface so that there is no way it can fall off.

If the machine is placed on a mobile undercarriage, the locking devices on the wheels of the undercarriage must be locked, i.e. pressed downwards. A suitable undercarriage for your machine is available as optional extra.

The machine must be placed in a well-aired and dry room. Avoid direct contact with water or steam.

In order to ensure correct operation of the machine, the room temperature must lie between +10° - +30° C.

There should be a gap of approx. 10 cm all around the machine. This is to prevent the machine overheating if on continuous duty.

Ensure that the supply lines cannot be damaged (e.g. by getting trapped between objects or being run over with heavy transport trucks).

#### **Machines with gas flushing/compressed-air devices:**

It is essential to ensure that the gas bottles are firmly secured and in a safe position!

### **2.2.2. Safety instructions for commissioning the machine post-delivery or post-relocation**

Carry out an initial check to ensure that the machine has not incurred any damage during transit or while being moved.

- Check the supply lines and connectors of the machine.
- Check the glass pane, the lid and the chamber(s).

Bear in mind that when generating a vacuum, the chamber, lid and glass pane are subject to a pressure of up to 1 kg/cm<sup>2</sup>. With a surface area of 50 cm x 50 cm, this is equal to 2,500 kg.

**Never use a machine that has been damaged during transit, while being moved around or by falling objects.** The chamber could implode, which would cause the glass pane in the chamber to shatter. The flying shards would represent a serious risk of injury. It would also cause damage to the machine and the packing goods.

#### Warning!

Damaged glass panes/machine lids must be replaced immediately!

---

**The machine should only be connected by a fully qualified technician.**

The machine is supplied already fitted with a plug.

#### Warning!

The power source of the machine must be protected over a residual-current circuit-breaker (RCCB) with a 30 mA tripping current.

Failure to comply with these instructions means there is a serious risk of injury from electrical shock if a machine is defective.

The electrical protection of the machine through the power source fuse system must be in accordance with the machine rating.

It is therefore essential to refer to the specifications on the rating plate of the machine.

### Electrical connection of machines that require three-phase current (power current):

In the case of machines with three-phase current connection, the direction of rotation of the vacuum pump motor must be taken into account.

If the motor turns in the wrong direction, the machine will not generate a vacuum (the lid is not suctioned into place when closed!).

The correct direction of rotation of the motor pump is indicated by a rotation arrow.

If the direction of rotation is wrong, this can be corrected by swapping the two current-carrying cables in the plug (polarity reversal).

You can reverse the polarity of most connectors at the phase inverter.

To do this, insert a screwdriver at point 1 on the pulled-out connector, push down and rotate.

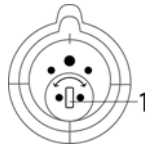

To check the direction of rotation, make sure that you only briefly switch the machine on and off.

Allowing the pump to run in the wrong direction of rotation for an extended period can cause damage to the pump.

In the case of machines that can be operated with alternating current, it is not necessary to check the direction of rotation.

---

### Machines with gas flushing device:

If the gas to be used for the vacuum packing is to be pure oxygen (O<sup>2</sup>) or a gas mixture with at least 21 % oxygen, the machine must be fitted with a special pump.

If standard vacuum pumps are used, there is a **danger of explosion !!!!**

The gas bottle is connected at the back of the machine. The connection provided for this purpose is designed for hoses with an inner diameter of 10 mm.

The minimum gas pressure is 1 bar, the maximum is 2 bar. If necessary, a pressure reducing valve must be fitted to reduce the gas bottle pressure.



### **2.2.3. Safety instructions for working with the machine**

**The machines must only be operated by fully trained and authorized persons.**

Before you begin working with the machine, check the lid and the glass panes for damage and cracks.

If you find any signs of damage you must not use the machine.

If you are working with gas, you must ensure that you only work with pure oxygen (O<sup>2</sup>) or with a gas mixture that contains more than 21 % oxygen, and your machine must be fitted with a special pump.

If the machine is fitted with a standard pump, you must not use pure oxygen or a gas mixture with such a high percent of oxygen!

**Danger of explosion!**

Always ensure that fingers, hands and other parts of the human body are kept clear when closing the machine lids to prevent the risk of entrapment between the lid and the chamber.

It is also essential to ensure that there are no other persons in the danger zone.

**Danger of entrapment!**

If working at high speed (or in the event of an operating error) the welding bar can get very hot. Do not touch the welding bar.

**Danger of burns!**

Ensure that the specified oil changes and oil filter changes are carried out regularly.

Failure to comply may result in the output of noxious oil fumes.

**Sensitive products:**

Before packing products, make sure that the product cannot be damaged by the high pressure generated by the vacuuming process.

Otherwise, a machine with a gas flushing device must be used.

If you are working with gas, you must ensure that there is always a residual vacuum of 20 % / -0.2 bar. The machine lids could otherwise spring open prematurely.

**Risk of injury!**

As soon as you remove the gassing nozzles from the machine, you must close the holes/drillings with the enclosed silicone caps because of reasons of hygiene!

The machine must be switched off at the main switch during interruptions in operation and at the end of operation. Depending on the machine type, the main switch is located on the left or right side of the machine.

If the machine is not used for longer periods of time, please also disconnect it from the main power supply.

#### **2.2.4. Safety instructions for servicing and cleaning the machine**

Always remove the mains power plug before carrying out any service or cleaning tasks.

Never clean the machine with a water hose or a steam jet device.

Only use solvent-free cleaning agents to clean the plastic lid of the machine. Solvents corrode the lid.

Damaged lids must be replaced immediately.

Risk of injury!

Regularly check (weekly) the state and level of the oil in the vacuum pump.

The vacuum pump is fitted with an oil inspection glass. This must not be more than  $\frac{3}{4}$  full.

If the level falls below the half-way mark, the oil must be topped up!

If the oil turns a whitish color after a while, an oil change should be carried out (see chapter 4.1. "Regular maintenance tasks")

Only food-safe oils may be used.

#### **2.2.5. Safety instructions for maintenance**

**Maintenance tasks should only be carried out by fully qualified maintenance engineers.**

Always disconnect the machine from the mains before carrying out maintenance tasks.

When working on the lid mechanism or spring mechanism, the machine lids – which can sometimes be very heavy – must be secured using suitable means. Otherwise, there will be a significant risk of serious entrapment injuries, e.g. if an unsecured lid were to fall shut.

When removing the lid springs, they must be detensioned as much as possible in order to reduce the force acting on the tensioning screw.

Otherwise, there will be a significant risk of injury caused by the springs and tensioning screw detensioning suddenly.

Some machine types can be opened up and folded out once the rear panel has been unscrewed.

The whole of the folded-out machine must be securely placed on a stable table!

If you have run the machine to warm it up prior to changing the oil, avoid contact with the hot oil.

Risk of burning!

## **2.2.6. Safety instructions for faults and repairs**

**Repair tasks should only be carried out by fully qualified engineers. Please contact us directly or one of our agencies.**

Always disconnect the machine from the mains before carrying out repair tasks.

When working on the lid mechanism or spring mechanism, the machine lids – which can sometimes be very heavy – must be secured using suitable means. Otherwise, there will be a significant risk of serious entrapment injuries, e.g. if an unsecured lid were to fall shut.

When removing the lid springs, they must be detensioned as much as possible in order to reduce the force acting on the tensioning screw. Otherwise, there will be a significant risk of injury caused by the springs and tensioning screw detensioning suddenly.

Some machine types can be opened up and folded out once the rear panel has been unscrewed.

The whole of the folded-out machine must be securely placed on a stable table!

If you have run the machine to warm it up prior to changing the oil, avoid contact with the hot oil.

Risk of burning!

## 2.3. Hazard warning signs

Your machine is fitted with the following hazard warning sign:



The sign is located at the back of the machine or is placed directly on the electrical control cabinet of the machine.

If any of the signs is damaged or is missing on the machine, it must be replaced immediately.

Please contact us if you require any replacement signs and we will be happy to provide them.

## 2.4. Emissions and disposal

Provided that the machine is working properly, the workplace-related noise emission value is less than 70 dB(A).

Please carry out the oil change and oil filter change as specified (see chapter 4.1. "Regular maintenance tasks").

Failure to comply may result in the output of noxious oil fumes.

If the machine is not supplied and erected by one of our agencies but supplied by a forwarding agent, please dispose of the packaging at a local collection point.

Used oil and oil filters should also be disposed of at a local collection point.

When you no longer have any use for your old machine you can return it to us and we will dispose of it for you free of charge.

Please contact us directly or one of our agencies.

### **3.0. Working with vacuum packing machines**

Once the machine has been erected and connected in accordance with sections 2.2.1. and 2.2.2., and the operator has familiarized him/herself with the instructions for safe operation of the machine (2.2.3.), you can start working with the vacuum packing line.

This chapter explains how to correctly adjust the machine control system. It shows how to place the vacuum bag in the chamber. It also describes the optional extras.

A further section provides instructions on how to pack liquids (soups, sauces, marinades, etc.).

### **3.1. Adjustment of the machine control system**

The vacuum packing line is available with a range of different control systems. The following sections describe the different types of control system.

#### **Control system models:**

- Control Z 1000 / Z 2000
- Control Z 2001 SENSOR
- Control Z 3000

You will easily recognize the control system type of your machine from the respective illustration.

#### **The following applies to all control system models:**

You will be able to see that you have set the correct sealing temperature because the weld seam on the bag is clear, blister-free and can no longer be opened by hand once it has been sealed.

Excess bag material can be torn off easily on machines with a cut-off seal.

The following basic principle applies when packing foodstuffs: the higher the vacuum, the longer the shelf life.

### 3.1.1. Control Z 1000 / Z 2000

Information: Control Z 1000 doesn't have pushbuttons DAL (3) and GAS (5).

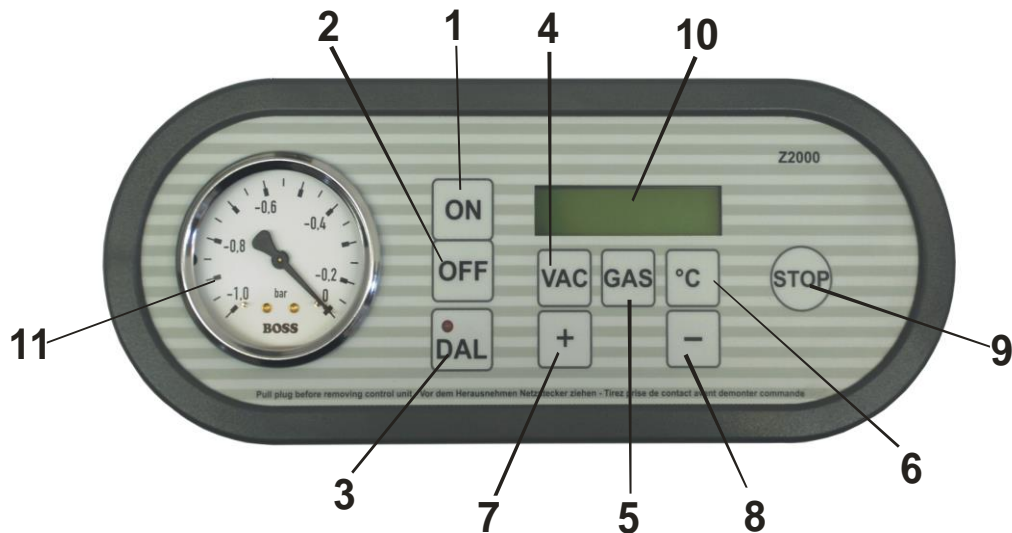

#### Please note:

- For machines without a gas flushing device set the gas value to 0.
- The control is a time-driven control system.

1) ON pushbutton	:	Switch on
2) OFF pushbutton	:	Switch off
3) DAL pushbutton	:	Continuous operation
4) VAC pushbutton	:	Vacuum
5) GAS pushbutton	:	Gas filling
6) °C pushbutton	:	Sealing temperature
7) “ + “ symbol	:	Pushbutton to increase value
8) “ - “ symbol	:	Pushbutton to decrease value
9) STOP pushbutton	:	Quick-Stop for packaging liquids (see 3.3.)
10) Display	:	Display field for displaying the set values
11) Vacuum meter	:	Vacuum display

## Adjustment of the Control Z 1000 / Z 2000

### a) Switching ON

With the lid open, switch the machine on by pressing the ON pushbutton 1).

You can see the set values in the display field 10).

### b) Vacuum value

Press the VAC pushbutton 4) and use pushbuttons 7) and 8) to set the required vacuum value (e.g. 25 seconds).

Press the VAC pushbutton again to confirm the set value.

### c) Gas filling

For machines without a gas flushing device (or for machines with a gas flushing device but where it is not to be used for a specific product) the gas value must be set to 0.

To set the duration of the gas filling process, press the GAS pushbutton 5) and use pushbuttons 7) and 8) to set the required gas value (e.g. 5 seconds).

Press the GAS pushbutton again to confirm the set value.

**The gas flushing device is an optional extra and must be ordered separately if required!**

### d) Sealing time

Press the C° pushbutton 6) and use pushbuttons 7) and 8) to set the required sealing time (e.g. 1.5 seconds).

### e) STOP pushbutton

By pressing the STOP pushbutton 9) you can prematurely interrupt the vacuum process and the vacuum bag is sealed immediately.

When packaging liquids, this can prevent the leakage of liquid from the vacuum bag (see 3.3.).

The machine should have reached at least 40 % vacuum before you press the STOP pushbutton. You can see the current level of vacuum on the vacuum meter 11).

### f) Continuous operation

When you press the DAL pushbutton 3) the pump runs continuously.

Before starting work, run the machine approx. 1-2 minutes, and before an oil change 5-10 minutes, to warm it up.

This warm-up should be carried out with the chamber lid closed.

### g) Switching OFF

The control system is switched off using the OFF pushbutton 2).

The machine must be switched off at the main switch during interruptions in operation and at the end of operation. Depending on the machine type, the main switch is located on the left or right side of the machine. If the machine is not used for longer periods of time, please also disconnect it from the main power supply.

### 3.1.2. Z 2001 SENSOR control system

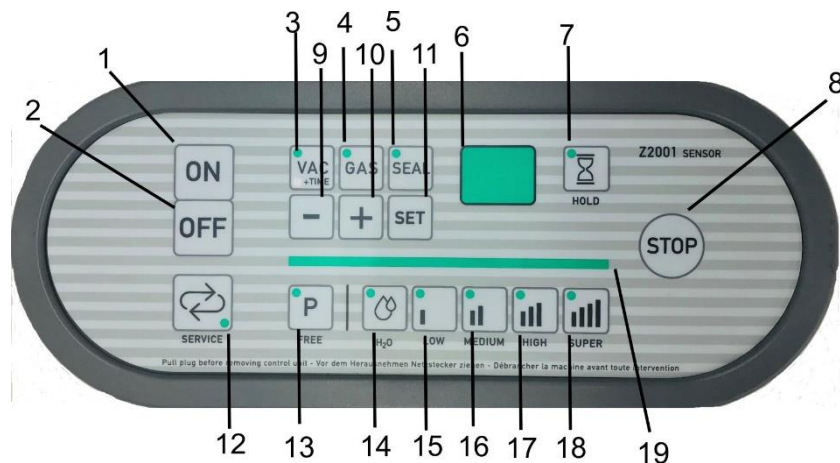

#### Please note:

- For machines without a gas flush device, leave the gas value at 0. We have already pre-set the control system to 0.
- In the Z 2001 SENSOR control system, the vacuum and gas values are measured using a sensor. This ensures that these values are always maintained precisely.

- |                        |   |  |
|------------------------|---|--|
| 1) ON pushbutton       | : | Switch on  |
| 2) OFF pushbutton      | : | Switch off   |
| 3) Pushbutton          | : | Vacuum   |
| 4) Pushbutton          | : | Gas  |
| 5) Pushbutton          | : | Sealing time (sealing temperature)   |
| 6) Field               | : | Display field  |
| 7) Pushbutton          | : | “Hold” = waiting time under vacuum before the bag is sealed                |
| 8) STOP pushbutton     | : | Interrupts the vacuuming process and immediately seals the bag shut        |
| 9) “-” pushbutton      | : | Pushbutton to decrease value   |
| 10) “+” pushbutton     | : | Pushbutton to increase value   |
| 11) SET pushbutton     | : | Saves programs;<br>hold down for four seconds until the pushbutton flashes |
| 12) SERVICE pushbutton | : | Continuous operation or servicing of pump                                  |
| 13) P pushbutton       | : | Program memory   |
| 14) Pushbutton         | : | H <sub>2</sub> O = 70% vacuum for packing liquids                          |
| 15) Pushbutton         | : | LOW = 80% vacuum (low vacuum)  |
| 16) Pushbutton         | : | MEDIUM = 98% vacuum (medium vacuum)  |
| 17) Pushbutton         | : | HIGH = 99% vacuum (high vacuum)  |
| 18) Pushbutton         | : | SUPER = over 99% vacuum<br>(very high vacuum with shut-off delay)          |
| 19) Line of luminaires | : | Vacuum display   |



## Adjusting the Z 2001 SENSOR control system

### a) Switching ON

With the lid open, switch the machine on by pressing the ON pushbutton 1). Wait five seconds until the control system is ready to run.

### b) Vacuum value

Use the pushbuttons 14) to 18) to set the required vacuum value.

Pushbutton 14) "H <sub>2</sub> O"	= 70% vacuum, e.g. for packing liquids. Caution! Only pack cold liquids. Follow the instructions in chapter 3.3.
Pushbutton 15) "LOW"	= 80% vacuum; low vacuum
Pushbutton 16) "MEDIUM"	= 98% vacuum; medium vacuum
Pushbutton 17) "HIGH"	= 99% vacuum; high vacuum (the HIGH program is used very often.)
Pushbutton 18) "SUPER"	= 99% vacuum + 10 seconds' additional vacuum time (+ TIME); very high vacuum

### Information:

We have applied default settings to the machine. Gas filling is set to 0 and sealing to 1.3. The machine is thus ready to run.

### c) Gas filling

For machines without a gas flush device (or machines with a gas flush device but where a specific product cannot be filled with gas), the gas value must be set to 0 in the display field 6) using the GAS pushbutton 4) and the +/- pushbuttons 9) and 10).

You can set your own gas value. As an average value, the display can be set to 50. The higher the set value, the higher the proportion of gas in the vacuum pack.

**The gas flushing device is an optional extra and must be ordered separately if required!**

The vacuum has to be set to at least 81% in order to adjust a gas value.

### d) Sealing time

Use the SEAL pushbutton 5) and the +/- pushbuttons 9) and 10) to set the required sealing time in the display field 6).

The setting range is between 0 and 4 seconds.

1.3 can be set as the average value.

Hold the SET pushbutton 11) down for four seconds to save your settings.

If your machine has a cut-off seal, you can tear off the surplus amount of bag end by hand. If you are unable to do so, you will have to increase the sealing temperature slightly.

e) SERVICE

If you hold down the SERVICE pushbutton 12) and close the chamber lid, the machine will run in service mode for 15 minutes.

The machine will run in continuous operation for the first five minutes, after which an intermediate ventilation will be added in at one-minute intervals. You can interrupt the process at any time using the STOP pushbutton 8). For instance, you can let the machine warm up if the room is cold. If the machine does not see much use, you should run the SERVICE program once a week. This will benefit the vacuum pump and the quality of the oil.

f) STOP pushbutton

Pressing the STOP pushbutton 8) will interrupt the vacuum process prematurely and seal the vacuum bag immediately.

g) Program memory

You can make changes to the default programs H<sub>2</sub>O to SUPER 14) – 18). For instance, you can adjust the vacuum level, the gas value (only for MEDIUM, HIGH and SUPER) and the sealing temperature. Press the corresponding pushbutton – VAC 3), GAS 4) or SEAL 5) – and use the -/+ pushbuttons 9) and 10) to modify the value. Hold the SET pushbutton 11) down for four seconds to save the new value.

The P pushbutton 13) lets you set up to 99 programs of your own. Press the P pushbutton 13) and use the -/+ pushbuttons 9) and 10) to select a program slot. Enter your required values and hold down the SET pushbutton 11)

for four seconds. This saves the program.

h) + TIME

The “+ TIME”, i.e. the additional vacuum time, is pre-set to 10 seconds in the factory. If you want to change the “+ TIME”, the vacuum value must be set to 99%. Therefore, press the SUPER pushbutton 18) or create a program for 99% vacuum in the program memory P 13).

Then hold down the VAC pushbutton 3) until the red LED flashes. You can now choose a “+ TIME” between one and 20 seconds using the -/+ pushbuttons 9) and 10). Hold the SET pushbutton 11) down for four seconds to save the new value.

i) HOLD (marinating/deaerating)

Briefly pressing the HOLD pushbutton 7) activates the HOLD function, which is ideal for marinating food. For example, fill a vacuum bag with fairly cold marinade (has to be cool!) and put in a piece of e.g. meat. Remove the insertion plates from the machine if necessary, to prevent liquid from escaping from the bag.

Closing the chamber lid will run the marinade program for 10 minutes. The pores in the meat will open during this time, allowing the marinade to soak in more quickly. After 10 minutes, the vacuum bag will be sealed, and the chamber lid will open.

You can change the duration of the marinade program to anything between 10 and 30 minutes using the +/- pushbuttons 9) and 10). Hold the SET pushbutton 11) down for four seconds if you want to save your change.

You can also adjust the sealing time using the SEAL pushbutton 5) and the +/- pushbuttons 9) and 10). You will need to hold the SET pushbutton 11) down again for four seconds to save your settings.

#### Deaerating products

If you want to deaerate a product under a certain vacuum for a sustained period of time, e.g. for technical use, you can activate the deaeration function. Follow the instructions in chapter 3.3. on packing liquids!

Hold down the HOLD pushbutton 7) for around 20 seconds until it flashes. Use the +/- pushbuttons 9) and 10) to set the required run time between one and 99 minutes.

You can also modify the vacuum level and sealing time using the VAC 3) and SEAL 5) pushbuttons and the +/- pushbuttons 9) and 10). Hold the SET pushbutton 11) down for four seconds if you want to save the new values.

The product will be kept under vacuum for the set length of time. The machine checks the vacuum value every two minutes and starts up the vacuum pump automatically if required. At the end of the run time, the bag is sealed, and the chamber lid reopens.

#### j) Factory settings

You can reset the control system to its original factory settings. Please note that this will delete all programs and changes that you have made yourself. Press the SERVICE pushbutton 12) and hold it down. Switch the machine on by briefly pressing the ON pushbutton 1). Release the SERVICE pushbutton 12) after 30 seconds.

The control system has been reset to its factory settings.

#### k) Error messages

F 1: The specified vacuum value has not been reached.  
Please read section 5.0.3. of these operating instructions.

F 2: No gas is being supplied.  
- Check whether the gas bottle is empty or screwed shut.  
- A gas value has been set on a machine not supplied with extra "gas filling".  
Reset the gas value to 0.

#### l) Switching OFF

The control system is switched off using the OFF pushbutton 2).

The machine must be switched off at the main switch during interruptions in operation and at the end of operation. Depending on the machine type, the main switch is located on the left or right side of the machine. If the machine is not used for longer periods of time, please also disconnect it from the main power supply.

### 3.1.3. Control Z 3000

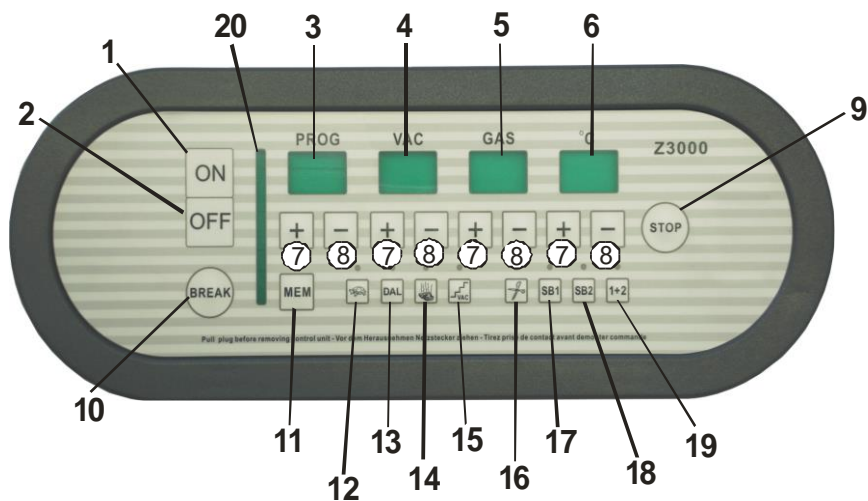

#### Please note:

- For machines without a gas flushing device set the gas value to 0.
- For Control Z 3000 the vacuum and gas value is measured over a sensor.  
This ensures extremely accurate adherence to the set values.

1) ON pushbutton	:	Switch on
2) OFF pushbutton	:	Switch off
3) Field	:	Program memory
4) Field	:	Vacuum display
5) Field	:	Gas display
6) Field	:	Sealing time
7) " + " symbol	:	Pushbutton to increase value
8) " - " symbol	:	Pushbutton to decrease value
9) STOP pushbutton	:	Interruption of vacuum process with immediate sealing of the bag
10) BREAK pushbutton	:	Interruption of the control cycle
11) MEM pushbutton	:	Storage of programs
12) "Turtle" pushbutton	:	Slow air release
13) DAL pushbutton	:	Continuous operation or servicing of pump
14) "Steam" pushbutton	:	Vacuum up to boiling point
15) "Steps" pushbutton	:	Step vacuum
16) "Shears" pushbutton	:	Switching on /Adjustment of cut-off seal
17) SB 1 pushbutton	:	Sealing bar 1 in operation
18) SB 2 pushbutton	:	Sealing bar 2 in operation
19) Pushbuttons "1+2 "	:	Sealing bars 1 and 2 in operation
20) Line of luminaries	:	Vacuum display

## Adjustment of the Control Z 3000

If the machine is connected to the main power supply, a green lamp indicates that the machine is ready to run.

a) Switching ON

With the lid open, switch the machine on by pressing the ON pushbutton 1).

b) Vacuum value

Use the pushbuttons 7) and 8) to set the required vacuum value in vacuum field 4). You can set the vacuum value within a range of 20 to 98 percent. If you set a vacuum higher than 98 %, the display switches over to millibar (mbar).

Thus, the value of 19 mbar appears next in display field 4) after the value of 98 %.

The setting of the highest possible vacuum is 1 mbar. Depending from product, humidity etc. it is not always possible to reach this set value. As guide number for the highest vacuum you may set a value between 10 and 5 mbar.

c) Gas filling

For machines without a gas flushing device (or for machines with a gas flushing device but where a specific product packing cannot be filled with gas) the gas value must be set to 0 in the display field 5) using the pushbuttons 7) and 8).

The gas value can be set within a range of 0 to 80.

As an average value, the display can be set to 50. The higher the set value, the higher the proportion of gas in the vacuum packaging.

**The gas flushing device is an optional extra and must be ordered separately if required!**

d) Sealing time

Use pushbuttons 7) and 8) to set the required sealing time in the display field 6). The setting range is between 0 and 4 seconds. 1.5 can be set as the average value.

Only applies to machines that are ordered with individually adjustable cut-off seal

In the case of machines with individually adjustable cut-off seals, the temperature of the cut-off seal can be set independently of the sealing bar.

For this purpose, the pushbutton 16) must be pressed and held. Then use pushbuttons 7) and 8) to set the temperature of the cut-off sealer bar in the display field 6).

1.3 can be set as the average value.

If the cut-off sealer is not required, you can press pushbutton 16) to completely switch it off.

e) Sealing bar circuit

If the machine is fitted with more than one sealing bar, you can use pushbuttons 17), 18) and 19) to select whether you want to switch on only one sealing bar (SB1 or SB2) or both sealing bars (1+2).

f) Continuous operation / Service program

In order to warm up the machine, (e.g. if the room is cold - for approx. 2 minutes), you can use pushbutton 13) to activate the continuous operation function.

This warm-up should be carried out with the chamber lid closed.

Press pushbutton 13) to activate the Service program for the pump (see section 4.1.1.).

g) Slow air release

Use the pushbutton 12) to select the speed of the chamber ventilation. If the slow air release function is switched on, the ventilation time is longer. This function is used for products that are particularly sensitive to pressure.

**Slow air release is available as an optional extra. For this reason, it can only be activated over the control system if you ordered the slow air release function.**

h) STOP pushbutton

By pressing the STOP pushbutton 9) you can prematurely interrupt the vacuum process and the vacuum bag is sealed immediately.

i) BREAK pushbutton

By pressing the BREAK pushbutton 10) you can prematurely interrupt the vacuum process without the vacuum bag being sealed.

j) Program memory

Using the MEM pushbutton 11), you store up to 99 programs for future use. Use the pushbuttons 7) and 8) to select a memory location between 1 and 99. Set the required values at the control system. Press the MEM pushbutton until the program memory display 3) PROG flashes twice. The program is now stored in the selected program memory location.

k) Step vacuum

You also have the option to generate the vacuum in steps.

This allows enough time for the air to escape from the product.

For machines that have a gas flushing device, you can gas-flush the product.

The step vacuum, i.e. the vacuum and gas cycles, are switched on or off by pressing the "Step" pushbutton 15) (LED on the ON/OFF pushbutton).

You can also program the cycles by pressing the "Step" pushbutton 15). The display fields for vacuum, gas and sealing time 4), 5), 6) indicate the cycle values for vacuum and gas and the idle time between the individual cycles (display field °C 6) ).

By holding the "Step" pushbutton 15) pressed, you can set the cycle values between 0 and 5 and the idle times between 0 and 60 seconds. If two cycles are set, the vacuum process runs directly through to the end vacuum. After the idle time, this process is repeated if the end vacuum value is no longer indicated.

If more than two VAC cycles are set, the end vacuum process is generated in one to three steps, each followed by an idle time. This is followed by the gas flushing process.

The VAC/GAS cycles can be set to repeat between one and five times. The number of cycles is indicated in the display field GAS 5). The idle time is indicated in the display field °C 6).

l) Vacuum up to evaporating point

Please refer to section 3.3. of these operating instructions.

Caution! Only pack cold liquids!

Under vacuum, liquids begin to boil faster than under normal pressure conditions. The colder the liquid that you are packing, the higher the vacuum you can achieve. Temperatures around 6° Celsius are ideal. If you press the "Steam" pushbutton 14), the machine automatically switches to the next step as soon as the liquid begins to steam. If you are packing normal, dry products, please switch off the "Steam" pushbutton.

Via the "Steam" pushbutton 14) you also can adjust the sensitiveness / the response. For this purpose, the pushbutton 14) must be pressed and held. Then use pushbuttons 7) and 8) to set the sensitiveness in the display field 6).

Value 0,1 in display field 6) = high sensitiveness

Value 9,9 in display field 6) = low sensitiveness

(Guide number for liquids with a temperature of approx. 15°C = 1,0 )

m) Pushbutton lock

The pushbutton lock can be switched on and off by pressing the STOP pushbutton 9) while switching on the machine using the ON pushbutton 1) and holding it down until the display shows **FrEI** (= *unlocked*) or **GESPErr** (= *locked*).

You must continue to hold down the STOP pushbutton 9).

Using the pushbuttons 7) and 8) under the display field °C 6), you can switch the pushbutton lock on and off.

If the pushbutton lock is activated (display: GESPErr); you can only use the MEM+, MEM-, STOP and BREAK pushbuttons.

n) Operating hours meter / cycle meter

The machine is equipped with an operating hours meter and a cycle meter.

**Operating hours for machines with pumps  $\leq 63 \text{ m}^3/\text{h}$ :**

If the DAL pushbutton 13) is pressed and held for several seconds, the display indicates how long the pump has been running. The display indicates hours between 00-00-00-00 and a maximum of 99-99-99-99.

**Operating hours for machines with pumps  $\geq 100 \text{ m}^3/\text{h}$ :**

If the "Turtle" pushbutton 12) is pressed and held for several seconds, the display indicates how long the pump has been running. The display indicates hours between 00-00-00-00 and a maximum of 99-99-99-99.

**Cycle indicator/ Sealing cycle**

If the "Steam" pushbutton 14) is pressed and held for several seconds, the display indicates how many times the machine has executed the sealing process.

The display indicates cycles between 00-00-00-00 and a maximum of 99-99-99-99.

**Resetting operating hours and cycle numbers**

The operating hours and sealing cycles can be deleted. First you need to call up the respective counter display. When you have the correct counter display, press the BREAK pushbutton 10) until the counter resets itself to 00-00-00-00.

o) Switching OFF

The control system is switched off using the OFF pushbutton 2).

The machine must be switched off at the main switch during interruptions in operation and at the end of operation. Depending on the machine type, the main switch is located on the left or right side of the machine. If the machine is not used for longer periods of time, please also disconnect it from the main power supply.



### 3.2. Creating vacuum packaging

The following section explains how to make vacuum packaging with and without gas filling.

#### Caution!

The vacuum bag must be placed on the sealing bar in the vacuum chamber as crease-free as possible.

If the vacuum bag selected is too small, this increases the risk of creasing.

It is important to ensure that the inside of the bag in the area where it will be sealed is kept clean (i.e. free of meat juice, fat, sauces, etc.).

When filling the bag with the product, fold the end of the open bag outwards to keep the sealing area of the bag clean.

#### Caution!

When manufacturing flat packs (such as cold cuts of meat, schnitzels, steaks) all the spacer plates provided are left in the machine.

In the case of thicker packages, you need to take as many spacer plates out of the chamber as necessary in order for the horizontal package to be placed so that half of it is above and half below the level of the sealing bar.

This is the best way to achieve a crease-free package and offers the best possible utilization of the bag.

#### **Vacuum packaging without gas filling**

Place the open, filled bag on the sealing bar.

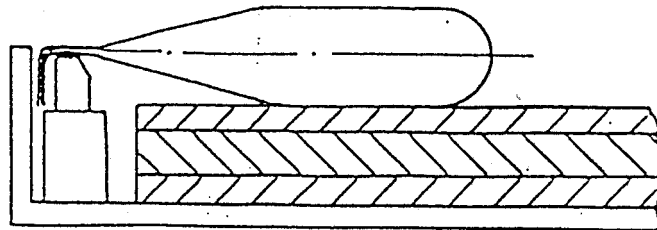

Smooth the bag out once you have placed it over the sealing bar.

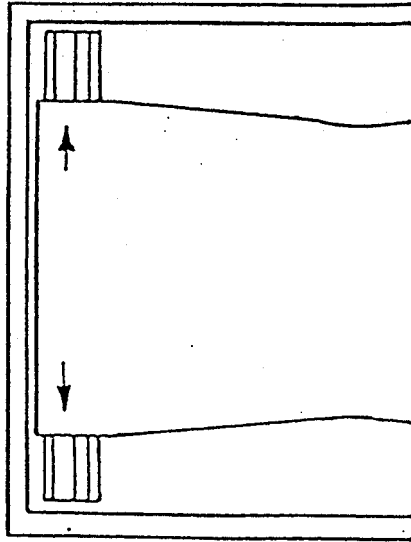

If the bag is more than 8 cm too long, we recommend cutting off the excess. Shorter lengths of excess bag can be pushed into the gap between the sealing bar and the chamber wall. However, please make sure that the air can still be easily pumped out of the bag.

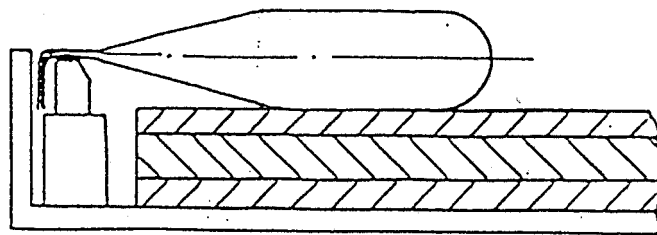

The bag opening should never be placed on the edge of the chamber as it would be pressed closed with the closing of the chamber lid. The air would then be unable to escape the bag during the vacuuming process. It goes without saying that the bag end should not be left hanging outside the chamber as this would render the vacuuming process impossible.

The operating cycle of the machine is started by closing the chamber lid.

## Vacuum packaging with gas filling

After packing, the vacuum packaging subjects the goods to an external pressure of up to 1 kg per cm<sup>2</sup>.

This could damage pressure-sensitive products; products with sharp corners and edges might poke through the vacuum bag, which would ruin the vacuum.

To prevent this and to obtain maximum use of the advantages of the vacuum packaging, a gas flushing device is used in such cases.

The function of the gas filling is to fill the inside of the packing with a gas that is adapted to the product (modified atmosphere). The gas in the bag counterbalances the external air pressure, which could damage the product or the bag.

With this sort of packaging, therefore, the air is not just withdrawn, but the goods are also placed in a "modified atmosphere".

If the machine is equipped with a gas flushing device, there are several gas flushing nozzles behind the sealing bar in the vacuum chamber.

The vacuum bag is placed on the sealing bar (as described above) and the gas flushing nozzles are fed into the mouth of the bag.

Please make sure that

- the bag is as crease-free as possible in the sealing area,
- the vacuum bag is not too short, which would increase the risk of creasing,
- the bag is not overfilled as there is otherwise no space for the gas around the product,
- you generate maximum vacuum before beginning with the gas filling (wherever possible) so that there is no residual air in the bag.

The set level of vacuum and the duration of the gas filling must be coordinated.

During gas-filling, there must always be a residual vacuum of 20 % / - 0.2 bar (this is indicated on the LED line or on the vacuum meter) as otherwise the sealing device of the machine cannot work properly. There is also a risk of the machine lid springing open mid-process.

The lower the vacuum in the chamber, the higher the temperature of the sealing wires. During gas filling, the vacuum in the chamber is always lower than when working without gas filling.

It therefore follows that you need to lower the sealing temperature accordingly when working with gas filling.

Tip: The gas nozzle strip in the machine is a plug-in model. When you are not working with gas filling, you can therefore simply unplug the strip and remove it. This makes it easier to insert the vacuum bag.

## **Top / bottom sealing or individually controllable cut-off seal**

If your machine is equipped with top / bottom sealing or individually controllable cut-off seal, the vacuum packaging is produced as described above.

The optional extra top / bottom sealing is designed for sealing very thick multilayer or aluminum bags.

This means that when the bag is being sealed, it is heated from both sides.

The individually controllable cut-off seal is used when the residual bag piece is to be cut off from the bag.

Please refer to section 2.2.2. of these operating instructions.

### **3.3. Information on the packing of liquids**

When packing liquid goods (soups, sauces, marinated meat, etc.) it is important to ensure that the vacuuming process is interrupted at the right time. Liquids froth up under vacuum. This effect is triggered by the reduction of the atmospheric pressure in the vacuum chamber.

When the liquid bubbles up, there is a risk that liquid will escape the bag. This causes loss of material and soils the vacuum chamber.

The vacuum packing line is fitted with a special switch for packing liquids. A large inspection glass in the chamber lid allows the packing goods to be monitored during the vacuuming process. (Viewing panels can be supplied as an extra for machines with stainless steel lids.)

If you see the liquid bubbling up in the vacuum bag, immediately press the "QUICK-STOP" or "STOP" pushbutton.

This immediately halts the vacuuming process and seals the bag. This prevents any liquids escaping from the packing goods.

If you are producing a large number of liquids packing goods of the same size, – after observing several packages and noting the level at which the product begins to bubble up and the vacuuming process would need to be interrupted – you can set the required level of vacuum at the control system.

The vacuuming process is then interrupted at the right time by the control system.

For machines that have a Control Z 3000, the control system automatically recognizes the boiling point of the liquid and switches to the next step of the operating cycle (see section 3.1.3.).

Please note:

Never pack warm or hot liquids as these will bubble over immediately when placed under vacuum!

Allow the liquids too cool down before packing.

The lower the temperature of the packing liquid, the later the liquid will begin to bubble up. This lengthens the vacuum time, thus increasing the level of vacuum that can be achieved and the shelf life of the product.

Temperatures around 6° Celsius are ideal.

Information:

**Boiling point of water under vacuum**

- At 60 % vacuum, the water starts to boil at 76°C.
- At 90 % vacuum, the water starts to boil at 45°C.
- At 99 % vacuum, the water starts to boil at 7°C.

When packing liquids and powdered products, we recommend the use of a special angular insert with adjustable bag stopper (available as optional extra). This insert is placed in the vacuum chamber and serves to fix the bag at an angle so that the liquid or powder cannot escape so easily.

The angular inserts are available in various sizes and versions.

#### **4.0. Regular cleaning tasks**

In order to prevent nucleation, we recommend cleaning the vacuum chamber and the spacer plates daily. For this purpose, use warm water with a commercially available cleaning agent and wipe the machine with a damp cloth.

Regularly clean the edge of the chamber that supports the lid and the rubber seal in the lid in order to ensure that the machine remains air-tight.

Regularly apply talcum powder (skin powder) to the lid seal so that it does not stick to the edge of the chamber.

This considerably extends the service life of the seal.

Only use solvent-free cleaning agents to clean the plastic lid of the machine. Solvents corrode the lid.

Damaged lids must be replaced immediately.

Risk of injury!

#### **4.1. Regular maintenance tasks**

**Please observe all safety instructions for maintenance work (chapter 2.2.5.).**

The vacuum packing line is extremely low-maintenance.

However, certain maintenance tasks should be carried out at regular intervals to ensure both the quality of the vacuum packaging and to extend the service life of the machine.

Carry out an oil change every 6 months.

If the vacuum pump accidentally sucks up water, dirt, etc., or if the oil is a whitish color, an oil change must be carried out immediately.

At least once a year, replace the filter cartridges of the pump.

If oil fumes are escaping from the exhaust of the pump, the filter cartridges must be replaced immediately.

Regularly check the sealing bar and the lid seal for signs of damage, wear and tear or cracks.

The lid hinges, springs and entire spring mechanism are under high tension. Check these parts for wear and cracking every six months, relubricating the moving parts if required. The parts must be replaced without delay if they are cracked or show signs of wear. Otherwise, there may be a risk of serious entrapment injuries depending on the weight of the lid.

Assuming one-shift operation, the springs must be replaced at least every two years as a precaution.

#### **4.1.1. Vacuum pump (control, oil service, oil change, changing the filter cartridges)**

**Please observe all safety instructions for maintenance work (chapter 2.2.5.).**

The built-in vacuum pump is extremely rugged. It is essential to regularly check the oil as it is crucial to the level of vacuum that can be achieved and the service life of the vacuum pump.

##### **Check**

At the oil container of the pump there is an oil inspection glass. This allows you to check the level and condition of the oil.

Use the maximum and minimum markings next to the inspection glass to check that the right level of oil is in the pump.

You can recognize the condition of the oil by the color. After absorbing moisture from the air, with time, the oil turns a whitish color and becomes more viscous. In this case, the oil must be changed.

##### **Oil service**

If your machine is equipped with a Control Z 3000, you have a service program for the pump. If you press the CONT pushbutton, the service program runs automatically. The lid of the machine must be closed for this purpose. The machine runs for 5 minutes, is subject to an intermediate ventilation, runs for 2 minutes, is subject to another intermediate ventilation, runs for 2 minutes, etc.

This process repeats 5 times and then the lid opens again. You should run this program weekly as it is good for the pump.

This program is also ideal for warming up the pump before the necessary oil changes.

##### **Oil change**

It is essential to ensure that only the following oil types are used in order to prevent damage to the vacuum pump. Please note the relevant filling levels for the pumps.

<b>Vacuum pump</b>	<b>Oil quality specified by the manufacturer</b>	<b>Oil quantity</b>
4 m <sup>3</sup> /h	VM 022	0,06 liters
8 m <sup>3</sup> /h	SAE 10,DIN 51 506, ISO VC 32	0,25 liters
10 m <sup>3</sup> /h	SAE 10,DIN 51 506, ISO VC 32	0,3 liters
16 m <sup>3</sup> /h	SAE 10,DIN 51 506, ISO VC 32	0,3 liters
21 m <sup>3</sup> /h	SAE 10,DIN 51 506, ISO VC 32	0,5 liters

If you have any trouble obtaining the specified oil, please contact us and we will be happy to supply you directly.

Before carrying out an oil change, you should run the vacuum pump warm for 5-10 minutes. This makes the oil less viscous so that it is easier to drain.

The chamber lid must be closed when warming up the machine!

Unscrew the oil-drain screw that is located next to the oil inspection glass and drain the oil into a container.

**Avoid contact with hot oil – risk of burning!**

Then re-tighten the oil-drain screw.

The oil-filling screw is located on the oil container. Unscrew this screw and fill up with fresh oil.

**Do not overfill!**

**The oil inspection glass must not be more than  $\frac{3}{4}$  full.**

Close the oil filling screw again.

Before starting up the machine again, make sure that the oil-drain screw and the oil-filling screw are screwed firmly back into place and are air-tight.



## **Changing the filter cartridges**

A filter cartridge is located behind the air outlet in the upper area of the oil container.

These filter cartridges prevent oil being blown out of the pump along with the outgoing air. The vacuum decreases with increasing age of the filter cartridges.

If this is the case, there will also be an increase in noxious oil fumes escaping from the air outlet.

If oil fumes are escaping, the filter cartridges must be replaced immediately. Otherwise, they should be replaced at least once a year.

- Unscrew the cover from the air outlet.
- Remove the flat tension spring holding the filter cartridge.
- Pull the filter cartridge towards the back and remove it from the oil container.
- Install the new filter cartridge and ensure that the seal (O-ring) is fitted properly on the end of the filter cartridge.

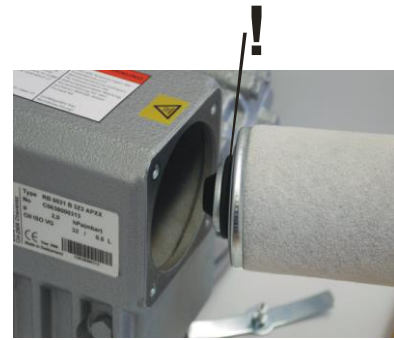

#### **4.1.2. Lid seal**

During the vacuuming process, the lid seal seals the gap between the lid and the vacuum chamber and is subject to heavy duty wear.

If the seal is damaged or showing signs of cracks, the machine will not reach its full vacuum capacity.

In this case, the seal must be replaced.

- Remove the defective seal from its groove.
- Carefully press the new lid seal into place in the groove - do not pull it!

We supply the lid seal as a ready-made sealing ring.

#### **4.1.3. Sealing bar (equipping the sealing bar)**

Please note: the sealing bar only requires approx. 30 V to operate.

The sealing wires located under the Teflon strip of the sealing bar are heated up for each sealing process and then cool down again. In doing so, they expand and shrink again.

Sealing wires and Teflon strip are working parts subject to wear and tear and must be replaced from time to time.

Either replace the complete sealing bar.

You can order a replacement bar from us. Send us your old sealing bar and we will send you a new replacement.

Or you can equip the sealing bar yourself.

In this case, you can also place an order with us for the necessary material (Teflon and wires).

#### **Equipping the sealing bar(s)**

- Remove the sealing bar from the machine.

Sealing bars located in the chamber lid can be removed using an Allen key (5 mm). A suitable Allen key is supplied with the operating instructions.

Sealing bars that are in the lower vacuum chamber are only plugged in and can be removed from the chamber without the need for tools

If the sealing bar of your machine is connected to the mains by cable, you need to remove the cable as follows:

Loosen the two slotted screws attaching the supply cable to the sealing bar. Red insulation disks are placed between the sealing bar and the cable lugs of the supply cable.

Take good care of these disks as reconnecting the supply cable without replacing the insulation disks will cause the machine to short-circuit.

If your machine is equipped with a cable-free power supply for the sealing bar, the above step can be omitted.

- Now remove the upper Teflon adhesive strip so that the heating wire is laid bare.
- Unscrew the screws on the left and the right of the sealing bar (at the ends of the sealing bar) holding the heating wire in place.

If these screws require an Allen key, this is included in delivery with the machine, if not, use a normal screwdriver.

- Remove the heating wire.
- Remove the Teflon strip.

You are now left with the bare metal bar.

- Thoroughly remove any residual pieces of adhesive and adhesive strip. The bar must be free of grease.

To refit the sealing bar, carry out all actions in the reverse order:

- First stick the first Teflon strip directly on the metal bar. The strip must be flush on both the right and the left and completely cover the area under the wire.
- Affix the heating wire to one side of the bar.
- Thread the wire through the slot on the other end of the sealing bar and tighten slightly, tighten the wire using a pair of (pointed) pliers and screw in tightly. Cut off any protruding wire ends.

- Stick on the second Teflon strip.
- In order to affix them to the chamber lid, you now need to cut out the holes for the Allen screws with a sharp knife.  
(Only applies to sealing bars located in the machine lid.)
- Use a sharp knife to cut the holes for the screws of the cable attachment and screw the supply cable back onto the sealing bar with the two slot screws.  
DO NOT forget the red insulation disks!  
The disks must be placed directly on the sealing bar.  
Then place the cable lugs on the disks and insert the slot screws.  
(only applies to sealing bars with power supply over cable.)
- Affix the equipped sealing bar back on the machine lid using the two Allen screws, or replace it back in the vacuum chamber.

**Example:**

Sealing bar with cable connection in a machine lid

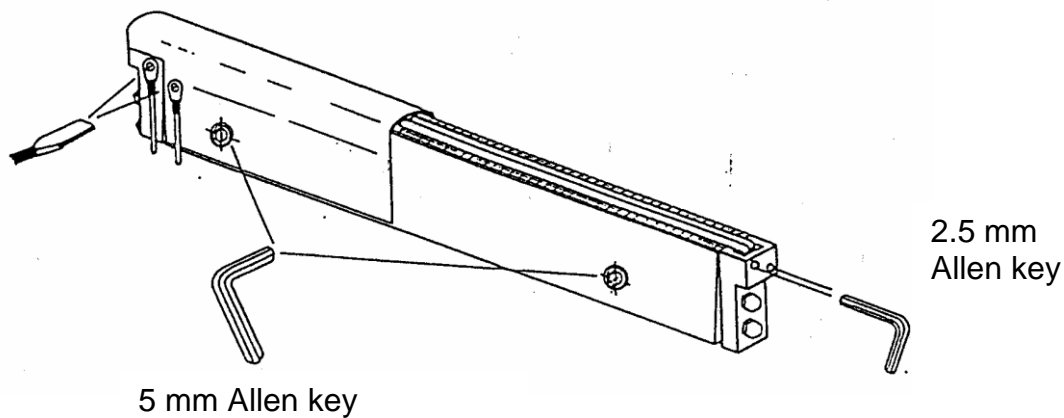

## **5.0. Faults and troubleshooting**

**Observe the safety instructions for faults and repairs (chapter 2.2.6.).**

**Repair tasks should only be carried out by fully qualified engineers.  
Please contact us directly or one of our agencies.**

### Warning !

If a machine is defective or if carrying out repair work - always disconnect from the main power supply.

### **5.0.1. Leakages**

The most frequent error messages refer to the fact that a part of the package is not airtight (leakages).

Please bear in mind that in this case, this problem is not usually the fault of the machine, but due to damage to the vacuum bag.

Even the best bag qualities have a reject rate of 2-3 % auf (mass production).

In other instances, the bags are often not placed in the vacuum chamber with sufficient care, which can cause damage to the bag.

The bags can also be pierced by the sharp or pointed edges of packing goods. A further reason for leakages may be that the sealing area of the bag is contaminated by meat juice, fat sauces etc. thus preventing a clean weld seam.

Therefore, if you have any problems with leaky packages, please try immersing the bag in clear water and lightly squeezing the package to find the leak.

The service man can only help if the weld seam is leaking, even though the sealing area of the bag was clean.

If you need to call the service man, please keep one of the faulty packages available for inspection to help us find the cause of the problem.

When contacting a member of our service team, it is always helpful to provide as accurate a description of the fault as possible.

### **5.0.2. Machine unable to create vacuum / loud sound from pump**

- If you have a machine with three-phase connection, please check the direction of rotation of the motor.  
The motor must turn in the direction of the arrow.  
(3-phase socket outlets are often not uniformly connected. If you relocate your machine and are using a new socket outlet, this may change the direction of rotation of the motor.)
- Check the house fuse and the in-house residual-current-operated circuit breaker (RCCB).

### **5.0.3. Poor vacuum**

- Are the vacuum chamber and insertion plates dry?  
Is the product damp and too warm?  
Liquids evaporate under vacuum and prevent the end vacuum from being reached.
- Check the level and quality of the oil.
- Check the lid seal for damage.

### **5.0.4. No welding seam on bag**

- Check the sealing wires on the sealing bar. These wires are wearing parts and must be replaced from time to time.

### **5.0.5. Bad welding seam**

- Check the sealing temperature and reset the "Welding" controller if necessary.  
If the sealing temperature is too low, it is possible to pull the weld seam of the bag apart again by hand, if the sealing temperature is too high, the weld seam is burned brown and small bubbles appear.
- Check the Teflon strip on the sealing bar.  
This strip is a wearing part and must be replaced from time to time.
- Check the silicone coating on the pressure bar.  
Replace if it shows signs of serious wear and tear (burning-in).

## 5.1. Removing of the machine control system

If you need to remove the machine control system, first disconnect from the main power supply.

Then undo the four screws of the machine control system to remove the control from the machine.

There are no screws on Controls type Z 2000 and Z 3000.

Proceed as follows with these control systems.

- 1.) Place screwdriver in the opening.
- 2.) Push the control system to the right by hand.

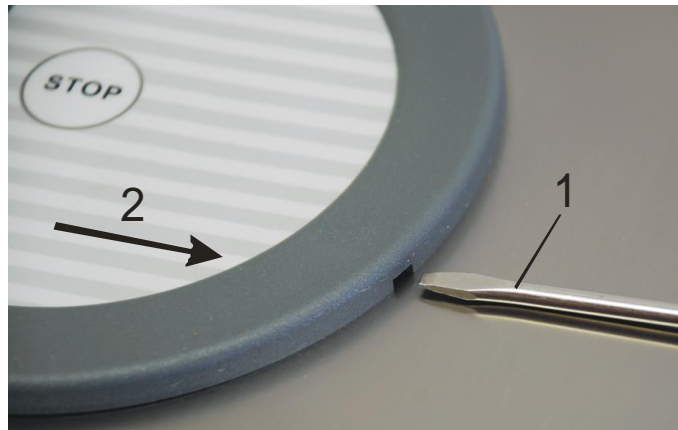

There is no need to unscrew any cables if removing a control system as they are simply unplugged!

## 6.0. Additional information for our service partners concerning Control Z 3000

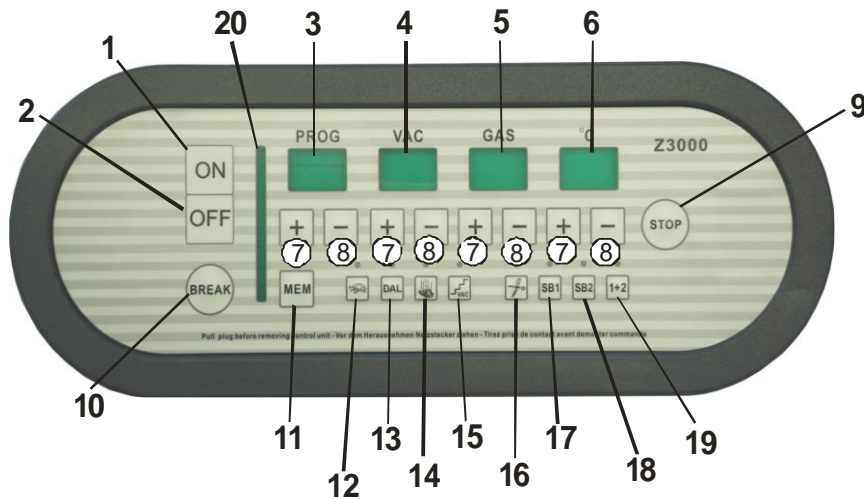

### A) Adjustment of sealing bars if sealing is unequal

#### Information:

It is just possible to adjust SB 2.

Example: If the machine is equipped with angle welding you can adjust the lateral sealing bar - make him stronger or weaker for e.g. 20 %.

- 1) ON
- 2) Press pushbuttons SB 1 and SB 2 simultaneously and hold them for approx. 10 seconds.
- 3) Use pushbuttons 7) and 8) to set the required adjustment in percent (e.g. – 20 %) in temperature field 6).

### B) Cool down time

- 1) ON
- 2) Press and hold pushbutton SB 2 for approx. 10 seconds.
- 3) Use pushbuttons 7) and 8) to set the required cool down time (e.g. 4 seconds) in temperature field 6).

### C) Basic setting

(e.g. if the control has been completely misadjusted)

- 1) ON
- 2) Press pushbuttons "STOP" and "BREAK" simultaneously and hold them for approx. 5 seconds.



#### **D) Setting the final point of vacuum**

Firstly connect the testing vacuum meter by a T-piece with the connecting hose leading to the control unit.

- 1) ON
- 2) DAL
- 3) Use pushbutton “+” below VAC to set 1 mbar (maximum value) and then hold the “+” pushbutton.
- 4) Close the lid.
- 5) As soon as the testing vacuum meter reaches 10 mbar shortly push „STOP“.
- 6) Confirm by shortly pushing “BREAK“.

#### **E) Changing the interval between cool down time and chamber ventilation**

- 1) ON
- 2) Push the pushbutton “1+2” and hold it.
- 3) Use pushbuttons 7) and 8) to set the time in temperature field 6).

#### **F) Reinjection push / chamber ventilation push**

- 1) ON
- 2) Press pushbutton 14 (Vaporisation point) and hold it for 5 seconds. As soon as the pushbutton is blinking, the reinjection push is activated.

#### **G) Sensibility of vaporisation point**

- 1) ON
- 2) Press pushbutton 14 (Vaporisation point) and hold it. Use pushbuttons 7) and 8) to set the sensibility in temperature field 6).

#### Information:

0,1 : high sensibility  
9,9 : low sensibility

As guide number for liquids with a temperature of approx. 15 °C we suggest setting the value “1,0”.

#### **H) Vacuum test (tightness test)**

From version 3.06 onwards, the Z 3000 control system comes with the new vacuum test feature. The control system version appears briefly on the display screen after the machine is switched on.

Make sure that the vacuum chamber is dry and empty of products before starting the vacuum test as it will be affected by moisture.

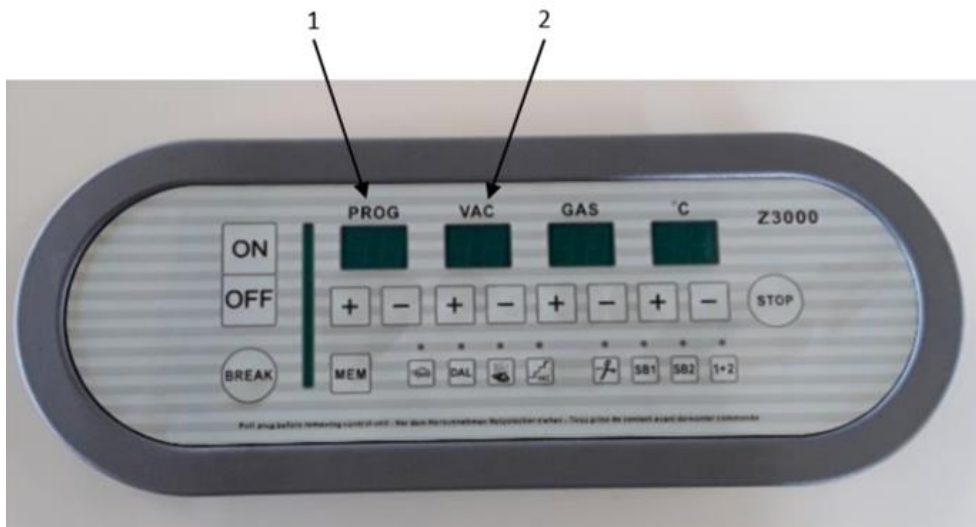

Now use the +/- pushbuttons to select programme 55 in the “PROG” display field (see Figure 1) and close the machine lid.

The machine will now attempt to generate a vacuum of 5 mbar. Once this figure of 5 mbar is reached, you will be able to see the vacuum value in mbar decrease for 10 seconds in the “VAC” display field (see Figure 2).

If the display field shows e.g. a value of 9 (i.e. 9 mbar) after 10 seconds, the vacuum has decreased by 4 mbar. This indicates a **minor** leak.

If the display field shows e.g. a value of 50 (i.e. 50 mbar) after 10 seconds, the vacuum has decreased by 45 mbar. This indicates a **major** leak.

If there is a **severe** leak, the control system will display the maximum value of 99 mbar.

The vacuum has decreased by 94 mbar **or more**.

If the leak in the machine is so extensive that the figure of 5 mbar stipulated for the vacuum test is not reached, the actual vacuum value achieved will be displayed after 2 minutes.

If you think that the vacuum value is decreasing too much, please contact our Customer Service team.

If you are dealing with a **major** or even **more severe** leak, please contact our Customer Service team without delay.